

Shields on Electric Posts Prevent Primate Deaths: A Case Study at Polonnaruwa, Sri Lanka

Wolfgang P.J. Dittus^{a-c}

^aSmithsonian Conservation Biology Institute, Washington, DC, USA; ^bNational Institute of Fundamental Studies, Kandy, Sri Lanka; ^cAssociation for the Conservation of Primate Diversity, Polonnaruwa, Sri Lanka

Keywords

Primate conservation · Human-monkey conflict · Primate electrocution · Polonnaruwa

Abstract

When monkeys, such as the toque macaques (*Macaca sinica*) of Sri Lanka, seek food on the ground near human habitation, they may use electrical posts to escape aggression from conspecifics, dogs, or humans. Shields mounted on electrical posts prevented monkeys from reaching the electrical wires, thereby averting their electrocution: the frequency of electrocutions ($n = 0$) was significantly less ($p < 0.001$) in the 12 years after installation of the shields than in the 12 years before ($n = 18$). Electric shocks were either fatal ($n = 14$) or caused permanent injury ($n = 4$) (collectively referred to as electrocutions hereafter). The shields may find broader applications in other primate species and environments wherever monkeys are attracted by human food near electrical posts. Primates and other arboreal mammals also accessed live wires from trees; at known electrocution hotspots, short spans of exposed wires were insulated by encapsulating them in PVC water pipes. It was impossible, however, to prevent electrocutions from all electric supply infrastructures that put monkeys at risk. A wider use of insulated electric conductors in planning power distribution in habitats frequented by wild animals would be desirable in preventing electric shocks to wildlife.

© 2020 S. Karger AG, Basel

Introduction

The expansion of human activity into wilderness areas brings in its wake ever increasing conflict between wildlife and humans, one aspect of which includes the electrocution of animals on power lines. Electrocutions have been documented for

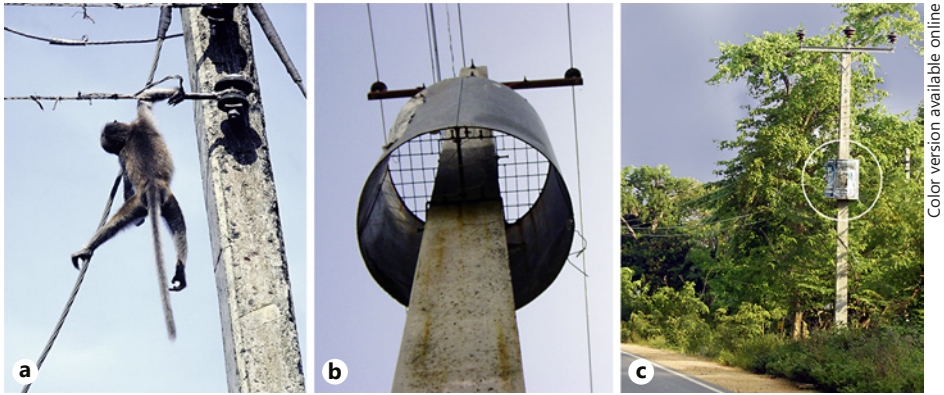

Fig. 1. Toque macaques were at risk of electrocution (a) when climbing electrical posts, but specially designed shields (b) mounted on electrical posts (c) prevented their access to the electrical wires and safeguarded them from electrocution (politicians posted their advertisements on the shields).

Asian elephants [Palei et al., 2014], raptors worldwide [Jenkins et al., 2010; Guil et al., 2011] as well as primates in Africa [Maibeche et al., 2015; Katsis et al., 2018], Latin America [Printes, 1999; Goulart et al., 2010; Rodrigues and Martinez, 2014], and Asia [Dittus, 1986; Rudran, 2007; Moore et al., 2010; Kumar and Kumar, 2015; Ram et al., 2015; Al-Razi et al., 2019]. To mitigate such events among primates, a variety of protective measures have been suggested including canopy bridges over power lines, tree trimming, wire insulation, and braiding of power lines [Valladares-Padua et al., 1995; Printes, 1999; Lokschin et al., 2007; Roscoe et al., 2013; Teixeira et al., 2013; Gregory et al., 2017].

In the interest of protecting valuable wildlife resources and preventing power outages, some electrical companies have devised ways of preventing wildlife electrocutions. The Wheatland Electric Cooperative, Inc. [2014], in the USA, for example, reports that insulated rubber-like bushing covers have been installed to cover transformer bushings and jumper wire tubing in areas frequented by squirrels and birds of prey and have slowed the number of wildlife electrocutions. Wrapping sheet metal around specific poles 3 m off the ground has proven effective in reducing the number of raccoon electrocutions. The sheet metal prevents the raccoons from climbing high enough to come into contact with the energized electrical lines.

Planning the mitigation of primate electrocutions on a broad scale involves the identification of electrocution hotspots for priority attention as has been done for birds [Tintó et al., 2010, Dwyer et al., 2014] and some primate species in Kenya [Katsis et al., 2018]. Guidelines for preventing the electrocution of wild primates are rare, however, and all too often no mitigation is planned. On a local scale, the method of mitigation should be adapted to the specific environmental and species circumstances.

Here I report on new methods to prevent electrocution among toque macaques (*Macaca s. sinica*) of Sri Lanka and potentially other monkey species elsewhere that face similar threats from the introduction of electrical wires into their environments.

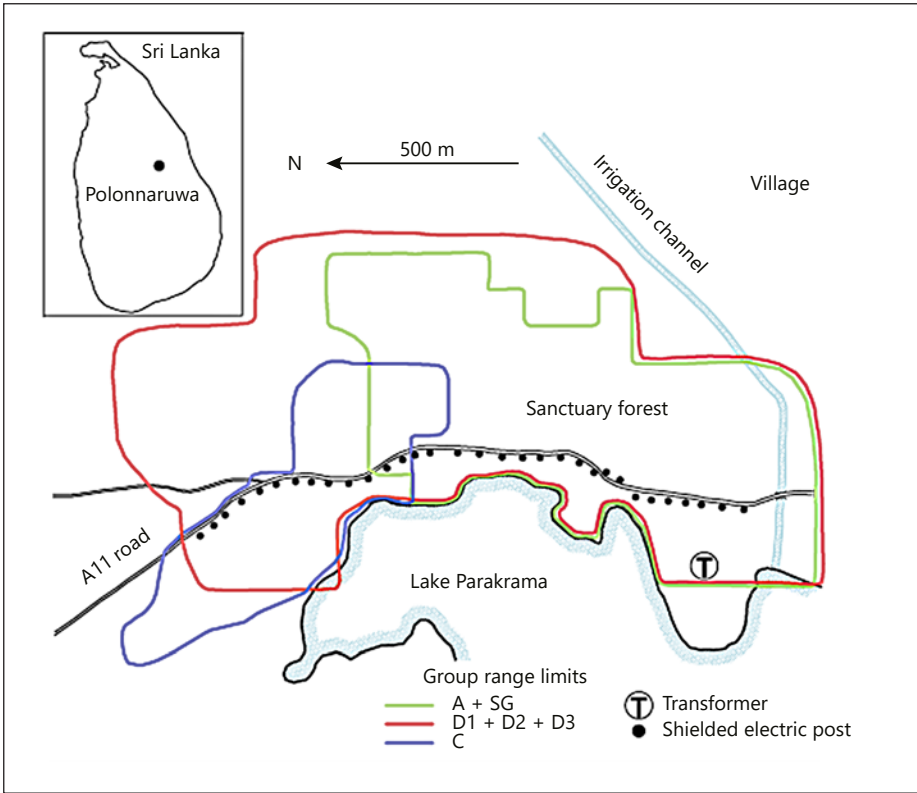

Color version available online

Fig. 2. Map of the south-western section of the study area at Polonnaruwa, Sri Lanka, where anti-electrocution shields were installed on 32 electric poles along highway A11 that cut through macaque home ranges.

Specifically, the threat was posed by uninsulated electric wires mounted on single poles as are commonly found in rural and urban primate habitats where monkeys are at risk of electric shock by climbing up the posts (Fig. 1a). Monkeys may also bite into insulated wires or contact uninsulated electric infrastructure from trees. Toque macaques inhabiting the Nature Sanctuary and Archaeological Reserve at Polonnaruwa, Sri Lanka, have been studied since 1968 to the present (2020). Four of the initial 18 study groups were subject to occasional electrocutions on power lines along a road that cut through a segment of these macaques' home ranges (Fig. 2). It was in the interest of the study and conservation to prevent such casualties. I aim to describe the design of "monkey shields" that prevented the macaques' access to the roadside power lines and to test the efficacy of the design by comparing the frequency of electrocutions for 12 years before and 12 years after the installation of the shields. It was not possible to insulate all electrocution hotspots including a transformer peripheral to the affected macaques' ranges (Fig. 2).

The other species of primates at the Polonnaruwa study site were two species of leaf-eating monkeys, the gray or Hanuman langur *Semnopithecus priam thersites* and

purple-faced langur *S. vetulus philbricki* as well as the nocturnal insectivorous slender loris *Loris lydekkarianus nordicus*. These species were generally not subject to electrocutions in the same manner that macaques were at the research site but were at risk in other areas of Sri Lanka [Nekaris and Jayawardene, 2004; Parker et al., 2008].

Methods

Research Site and Environs

The study population of macaques initially involved about 450 individuals that were distributed among 18 independent social groups [Dittus, 1977a]. Some of these groups had increased their numbers over the years, split into two or more daughter groups, a few became extinct, and new groups (of demographic and ecological interest) also were added to the original population sample [Dittus, 1988; Dittus et al., 2019]. Macaque density varied in space and time from 1 to 3 individuals per hectare, being greatest where macaques had regular access to human food scraps and the concomitant electric posts. The area occupied by the sum of the home ranges of all study groups ($n = 33$) was approximately 8.5 km² with a perimeter of approximately 18 km. Four of these groups, located in the south-western section of the sanctuary, were subject to electrocution on power lines that cut through the study area for about 1.5 km (1% of the perimeter). The main area of risk was along highway number A11 between the Hathamuna Junction and the bridge over the irrigation channel at the northern entrance to the old town of Polonnaruwa (Fig. 2). Along that strip of road, these were the only groups facing this risk apart from the occasional immigrant male from a neighboring group. The affected groups had been labeled as A, SG, C, and D. The groups A and SG fused in 1976 [Dittus, 1987], group C went extinct, and group D split into three daughter groups D1, D2, and D3 [Dittus, 1988]. The forest of the sanctuary was dry evergreen forest [Dittus, 1977b] and was bordered by partly inhabited secondary and scrub forest, a lake, and an irrigation channel.

Subsistence level households were scattered outside of the boundaries of the sanctuary, rice was cultivated in some areas of the surrounding region, and tourists visited sections of the site. Electric supply lines to individual buildings were insulated when feeding off the main line of bare wires. Notwithstanding, exposed wires with neglected branch trimming were encountered at a few places away from the roadside. At such sites, in addition to primates, other arboreal mammals were also at risk of electrocution, including giant squirrels (*Ratufa macroura*), palm squirrels (*Funambulus palmarum*), and flying-fox fruit bats (*Pteropus medius*).

Population Census

All macaques in the study groups were individually identified systematically from their natural markings, many had also been tattooed [Dittus and Thorington, 1981]. Macaques were censused at least once monthly and more frequently during the birth season. In this way, a log was kept of the number of months that known individuals were alive in each group. Casualties from electrocutions (Fig. 1a) were mostly known because they occurred in conspicuous places along the roadsides (Fig. 2) and the local community alerted the primatologists. Home ranges were monitored by charting range use on preprinted maps.

Results

Shield Design and Installation

The framework of the cylindrical shield was constructed of welded iron bars covered with an outer surface of galvanized tin sheet (Fig. 3). The cross-section dimension of the iron bars was ½ inch × ¼ inch (6.4 mm × 12.7 mm). The shield was con-

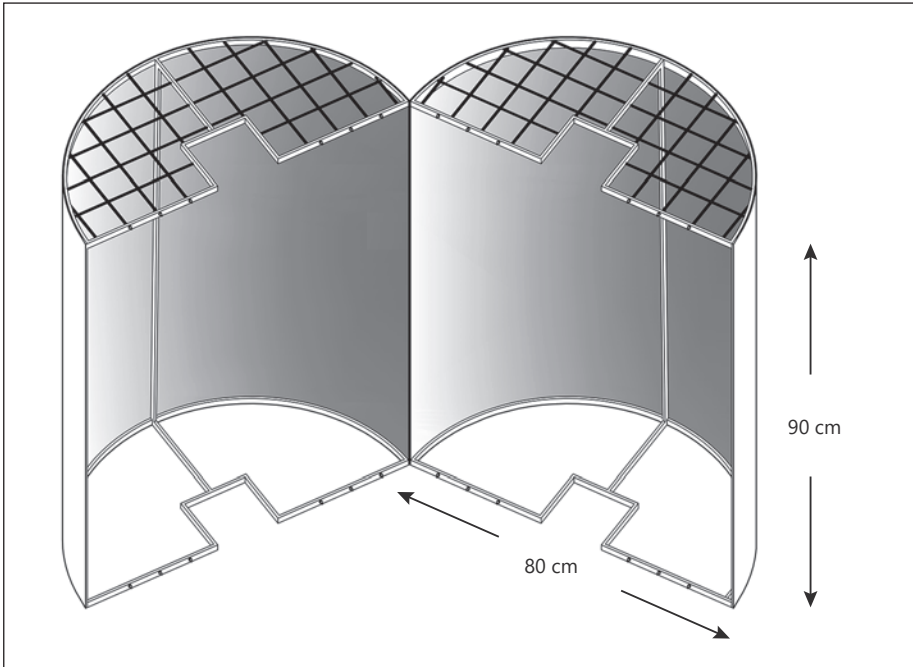

Fig. 3. The protective shield was constructed in two half cylinders that were joined together when mounted on a post with clamps located in the center of the top and bottom of the framework. The open bottom allowed monkeys' easy access to the interior of the shield but the mesh at the top prevented further ascent towards the electrical wires (drawing by Pulasthi Handunge).

constructed as two half cylinders hinged on one side and bolted shut when affixed to the electrical posts. Clamps in the center top and bottom of the cylinder held the shield to the posts (Fig. 1b). The mesh (7.5 cm × 7.5 cm) at the top of the shield was welded with 6-mm diameter iron rods. The outer surface of the shield was smooth and provided no hand holds. Bars of the frame and clamps crossed at right angles at the open bottom of the cylinder and offered easy grips to access the interior of the shield for monkeys climbing up the electrical pole. Shields were installed along the 1.5-km stretch of road where transmission posts were located, one shield per post (Fig. 1c); there were 32 installations (Fig. 2). The shields' lower edges were approximately 5 m above ground level. The Sri Lanka Electricity Board authorized and assisted with these installations and shut off the power transmission when shields were mounted onto the posts.

Testing Efficacy of Shields in Preventing Electrocutions

In the 12-year period preceding the installation of the shields, 18 macaques had been electrocuted. Four individuals survived the electrocution, but lost one or more of their limbs, the other 14 were fatal. In the 12-year period following installation, none were electrocuted along the shielded roadside. The focal groups grew over the

Table 1. Comparison of the number of monkeys electrocuted in the 12-year periods before (1975–1987) and after (1988–1999) the installation of the anti-electrocution shields in areas protected (A) and unprotected (B) by shields

	Before shield installation, <i>n</i>	After shield installation, <i>n</i>	Fisher exact test (<i>p</i>)
Monkey-months observed	9,538	18,684	
A Protected area			
Electrocutions observed	18	0	<0.001
Electrocutions expected	6	12	
B Unprotected areas			
Electrocutions observed	4	9	1.000*
Electrocutions expected	4	9	

* Not significant.

24-year period such that the numbers of macaques at risk changed through time [Dittus et al., 2019]. Therefore, I estimated the total number of months that each individual in the at-risk groups was observed before and after June 1987 when shields had been installed. A month of observation of a living monkey was considered as a monkey-month. Assuming a random model for the probability of being electrocuted at any time, the expected frequencies of casualties was estimated in relation to the proportion of time (monkey-months) that macaques were observed before and after shield installation. There were significantly ($p < 0.001$) fewer casualties after than before the protective shield installations (Table 1, part A).

Some electric shock casualties occurred among these groups at sites that could not be insulated. The frequency of electrocutions there increased over time in proportion to population numbers and bore no relation in space or time to shield installations along the roadside (Table 1, part B).

Other Protections

Outside and within the nature sanctuary, individual buildings were occasionally supplied with uninsulated wires strung through the forest where branch clearing was infrequent. Therefore, primates and other arboreal mammals were at risk of electric shock from wires accessed through branches. At high-risk sections, where wires were close to the trees, the wires were encapsulated in PVC water pipes (1.3 cm diameter). Normal electrical conduit tubing was considered too flimsy for this purpose. The PVC pipes were slit with a single cut along their length and simply pinched closed over the wires. Long sections of pipe, or two sections in tandem prevented their slippage along the wire (Fig. 4). Since their installation in 1986, the PVC pipes were still intact on the wires 34 years later with no intervening maintenance. No quantitative tests were carried out to test the efficacy of these encapsulated wires, but ad libitum observations suggest that electrocutions were prevented at these potential hotspots.

Juvenile macaques had a penchant for biting and licking insulated telephone wires presumably to experience the tingling of weak electric current; the behavior ap-



Color version available online

Fig. 4. Short segments of uninsulated electric cables that coursed near tree branches (**a**) were encapsulated in PVC water pipes (**b**) as a supplementary means to prevent monkeys and other arboreal mammals from suffering electrocution at sites where the trimming of tree branches was irregular.

peared playfully inquisitive. At the Smithsonian Primate Research Station (see Google maps), insulated electric wires were encapsulated in PVC pipes and linked underground between buildings. This prevented inquisitive macaques from biting the insulated wires: no electrocutions were observed there in 43 years (1977–2020).

Discussion

Context Leading to Electrocution

Toque macaques are long-tailed and anatomically adapted to move through the trees and on the ground [Grand, 1972, 1976]. They forage, rest, and sleep in the trees and come to the ground mostly to forage when food sources are most accessible at ground level [Dittus, 1977a]. They do not normally climb up transmission posts or contact electrical wires at the study site. The Sri Lanka Electricity Board regularly trimmed tree branches away from the main supply wires along the road to prevent outages, therefore monkeys' access to wires from tree crowns was minimal along the main roads. During the harvest season when rice was transported, small amounts of rice spilled onto the tarmac, people also littered their meal scraps, and these artificial foods attracted macaques to forage along the roadsides. When macaque fights and

chases erupted at such locales, the electric posts often offered the closest escape route upward off the ground, putting the subordinate escapee at risk.

Rationale for Shield Design and Adaptability

The shield's design required a block of access to the wires when an escaping macaque shinnied up the pole. The shield was left open at the bottom for easy access but was blocked by a wire mesh at the top (Fig. 1b, 3). The open mesh allowed the macaques to see the sky or tree canopy (freedom to escape higher) through the bole of the shield. The combination of a smooth outer surface of the shield that offered no hand grips, a diameter greater than stretched out limbs, and a height greater than adult body lengths prevented macaques from attempting to climb over the outer surface of the shield. Structural struts inside the shield, on the other hand, were easily accessed from the open bottom and offered a place to sit and cling. Very few monkeys attempted to skirt around the outside of the shield and those that did gave up and took the easy route to go inside the shield. The design was purposely sturdy to withstand the forceful south-west monsoon winds at Polonnaruwa. The shield design, however, is open to adaptation to local conditions; for example, the lower opening might be made wider than 80 cm diameter (creating a cone shape) to more easily accommodate larger-bodied monkeys, such as langurs.

Shield Use for Other Primate Species and Environments

The shields were an effective way to block macaques from being electrocuted under the conditions specified here. Comparable environmental and social contexts that lead to the risk of electrocution are, however, familiar for macaque species throughout Asia [Pirta et al., 1997; Eudey, 2008; Kumar and Kumar, 2015] and primates elsewhere [Lokschin et al., 2007]. Electrocution hotspots are common in towns and along rural roads where macaques are attracted by human food scraps, crops, and fruit trees and aggressive competition for food can occur at high rates at such spots [Southwick et al., 1976; Singh, 2019]. The shield design, therefore, may have a more general application, not only for macaques but also other ground- and tree-dwelling primates that face this threat in their environments [Boinski et al., 1998; Printes, 1999; Goulard et al., 2010; Lokschin et al., 2007; Maibeche et al., 2015; Ram et al., 2015; Al-Razi et al., 2019]. The shield design is suited for single posts (Fig. 1c) that are most widely used in rural or domestic settings; high-power pylons being excluded. In planning to safeguard monkeys and other wildlife from electrical wires, the installation of insulated wires may be more cost-effective. But that option may not be available where bare wires already are in place. Shields would offer an immediate safeguard until such a time that insulated wiring can be afforded and installed. Primatologists may follow the lead of ornithologists [e.g., Tintó et al., 2010; Guil et al., 2011] to identify electrocution hotspots where animals are most vulnerable and prioritize protective measures at these sinks [Teixeira et al., 2013].

The three other primate species at the Polonnaruwa site, the leaf-eating langurs and loris, were not attracted to roadsides to forage and therefore were less at risk in such a context. At other sites, however, slender loris were known to contact electrical wires from overhanging branches, being attracted to insects swarming around road lights (personal observation). Nekaris and Jayewardene [2004] reported that electrocution was the main known cause of loris mortality in areas of Sri Lanka that are heavily populated by humans. A similar threat has been reported for the critically endan-

gered purple-faced langur in the human-dominated landscapes of south-western Sri Lanka [Rudran, 2007; Parker et al., 2008; Roscoe et al., 2013]. The shields would offer little protection where wires are accessed through trees. Nevertheless, when the highly arboreal purple-faced langurs navigate their ranges through fragmented tree canopies [Moore et al., 2010], they are often left no option but to descend cautiously to the ground and dash at top speed to the nearest tree trunk [Grand, 1976; personal observation]; if the route ends at an electrical post, the shields could prevent electrocution.

Electric wires are commonly accessed from trees by arboreal mammals and pose a risk of electric shock if wires are not insulated. By law in Sri Lanka, electrical cables in wildlife protected areas are banned or require insulation. Similarly, electric supply to individual households normally are insulated to protect human residents. Occasionally, however, they were not. When exposed cables are strung over a short distance, as from a main transmission post to a building or between buildings, the wires might be insulated by manually encapsulating them in PVC water pipes. The pipes were simple to install and inexpensive. Over long distances of exposed wire, however, the use of either insulated wire and/or frequent tree trimming would seem more appropriate safeguards for arboreal animals as has been suggested elsewhere [Lokschin et al., 2007; Gregory et al., 2017]. At several South American sites, arboreal mammals have been provided safe passage between fragmented forest patches by way of rope canopy bridges that were strung above roads and/or electric power lines [Valladares-Padua et al., 1995; Lokschin et al., 2007; Teixeira et al., 2013]. Gregory et al. [2017] have shown that well-located canopy bridges were used with increasing frequency by multiple arboreal mammal species and presumably reduced electrocution casualties. The efficiency and cost-effectiveness of most mitigations have not been widely investigated and are expected to differ with the species, environment, and economic context. The methods described here were developed as immediate site-specific remedies where the prevention of monkey electrocutions (from exposed live wires) was not considered in the planning of electric power distribution. Despite the success of the anti-electrocution shields installed on electric posts at Polonnaruwa, it was impossible to protect monkeys from all risks of electric shock in the environment (Table 1, part B). Awareness of the general public and responsible authorities would be helpful in prioritizing budget allocations for efforts to mitigate wildlife electrocutions – most effectively by using insulated cables and terminals.

Conclusion

The shields prevented toque macaques from accessing electrical wires when climbing up the posts from the ground. I suggest that such shield designs offer protection from electrocution for other arboreal or semi-arboreal primates (having similar ecologies) when monkeys seek food on the ground near electrical posts and flee from aggressors (conspecifics, dogs, or humans) using these posts. Live wires accessed through trees also posed a risk. Short spans of uninsulated electric wires between posts might be encapsulated in PVC water pipes at sections where untrimmed tree branches provide arboreal mammals access to such electrocution hotspots. Ultimately, however, given the variety of electric supply configurations accessible to wildlife in the environment, wider use of insulated connections would appear most effective in ameliorating wildlife electrocutions.

Acknowledgements

I thank the directors of the National Institute of Fundamental Studies (NIFS) and the Smithsonian Conservation Biology Institute for administrative support. The Sri Lanka Electricity Board helped mount shields onto posts. For their years of dedicated service in data collection and/or summary I am indebted to A. Baker (1976–1983), N. Basnayake (1986–2005), UHL Chandra (1991–2020); V. Coomaraswamy (1989–2005); T. Diaz (1981–1997); S.M.S. Farook (1970–1978), S. Gunathilake (1986–2014), and V. Wijekulasuriya (2008–2020). Comments from the editor and three reviewers improved the manuscript.

Statement of Ethics

The research methods relating to the aims of this report were non-invasive and involved the observation of animals in their natural habitat. The installation of anti-electrocution guards in these animals' environment had no negative effect on animals.

Conflict of Interest Statement

The author has no conflicts of interests to declare.

Funding Sources

The study was funded mainly by grants from the US National Science Foundation (1976–1996), Earthwatch Institute (1992–2007), and the Association for the Conservation or Primate Diversity (2007–2020). The latter also supported the write-up phase of this report.

Author Contributions

The corresponding author is the sole author of this report.

References

- Al-Razi H, Maria M, Muzaffar SB (2019). Mortality of primates due to roads and power lines in two forest patches in Bangladesh. *Zoologia* 36: 1–6.
- Boinski S, Jack K, Lamarsh C, Coltrane JA (1998). Squirrel monkeys in Costa Rica: drifting to extinction. *Oryx* 32: 45–58.
- Dittus WPJ (1977a). The socioecological basis for the conservation of the toque monkey (*Macaca sinica*) of Sri Lanka (Ceylon). In *Primate Conservation* (Rainier PHS, Bourne GH eds.), pp 237–265. New York, Academic Press.
- Dittus WPJ (1977b). The ecology of a semi-evergreen forest community in Sri Lanka. *Biotropica* 9: 268–286.
- Dittus WPJ (1986). Sex differences in fitness following a group take-over among toque macaques: testing models of social evolution. *Behavioral Ecology and Sociobiology* 19: 257–266.
- Dittus WPJ (1987). Group fusion among wild toque macaques: an extreme case of inter-group resource competition. *Behaviour* 100: 248–291.
- Dittus WPJ (1988). Group fission among wild toque macaques as a consequence of female resource competition and environmental stress. *Animal Behaviour* 36: 1626–1645.
- Dittus WPJ, Thorington RW, Jr. (1981). Techniques for aging and sexing primates. In *Techniques for the Study of Primate Population Ecology* (Populations SoCoNP ed.), pp 81–134. Washington, DC, National Academy Press.
- Dittus WPJ, Gunathilake KAS, Felder M (2019). Assessing public perceptions and solutions to human-monkey conflict from 50 years in Sri Lanka. *Folia Primatologica* 90: 89–108.

- Dwyer JF, Harness RE, Donohue K (2014). Predictive model of avian electrocution risk on overhead power lines. *Conservation Biology* 28: 159–168.
- Eudey A (2008). The crab-eating macaque (*Macaca fascicularis*): widespread and rapidly declining. *Primate Conservation* 23: 129–132.
- Goulart VDLR, Teixeira CP, Young RJ (2010). Analysis of callouts made in relation to wild urban marmosets (*Callithrix penicillata*) and their implications for urban species management. *European Journal of Wildlife Research* 56: 641–649.
- Grand TI (1972). A mechanical interpretation of terminal branch feeding. *Journal of Mammalogy* 53: 198–201.
- Grand TI (1976). Differences in terrestrial velocity on *Macaca* and *Presbytis*. *American Journal of Physical Anthropology* 45: 101–108.
- Gregory T, Carrasco-Rueda F, Alonso A, Kolowski J, Deichmann JL (2017). Natural canopy bridges effectively mitigate tropical forest fragmentation for arboreal mammals. *Scientific Reports* 7: 3892.
- Guil F, Fernández-Olalla M, Moreno-Opo R, Mosqueda I, Elena Gómez M, Aranda A, Arredondo Á, Guzman JM, Oria J, Garcia LMG, Margalida A (2011). Minimising mortality in endangered raptors due to power lines: the importance of spatial aggregation to optimize the application of mitigation measures. *PLoS One* 6: e28212.
- Jenkins A, Smallie JJ, Diamond M (2010). Avian collisions with power lines: a global review of causes and mitigation with a South African perspective. *Bird Conservation International* 20: 263–278.
- Katsis L, Cunneyworth PMK, Turner KME, Presotto A (2018). Spatial patterns of primate electrocutions in Diani, Kenya. *International Journal of Primatology* 39: 493–510.
- Kumar V, Kumar V (2015). Seasonal electrocution fatalities in free-range rhesus macaques (*Macaca mulatta*) of Shivalik hills area in northern India. *Journal of Medical Primatology* 44: 137–142.
- Lokschin LX, Printes RC, Cabral J, Nunes Hallal, Buss G (2007). Power lines and howler monkey conservation in Porto Alegre, Rio Grande do Sul, Brazil. *Neotropical Primates* 14: 76–80.
- Maiheche Y, Moali A, Yahi N, Menard N (2015). Is diet flexibility an adaptive life trait for relic and peri-urban populations of the endangered primate *Macaca sylvanus*? *PLoS One* 10: e0118596.
- Moore R, Nekaris AKI, Eschmann CL (2010). Habitat use by western purple-faced langurs *Trachypithecus vetulus nestor* (Colobinae) in a fragmented suburban landscape. *Endangered Species Research* 12: 227–234.
- Nekaris AKI, Jayewardene J (2004). Survey of the slender loris (Primates, Lorisidae Gray, 1821: *Loris tardigradus* Linnaeus, 1758 and *Loris lydekkerianus* Cabrera, 1908) in Sri Lanka. *Journal of Zoology (London)* 262: 327–338.
- Palei NC, Palei HS, Kar CS (2014). Mortality of the endangered Asian elephant *Elephas maximus* by electrocution in Odisha, India. *Oryx* 48: 602–604.
- Parker L, Nijman V, Nekaris AKI (2008). When there is no forest left: fragmentation, local extinction, and small population sizes in the Sri Lankan western purple-faced langur. *Endangered Species Research* 5: 29–36.
- Pirta RS, Gadgil M, Karshikar AV (1997). Management of the rhesus monkey *Macaca mulatta* and Hanuman langur *Presbytis entellus* in Himachal Pradesh, India. *Biological Conservation* 79: 97–106.
- Printes RC (1999). The Lami Biological Reserve, Rio Grande do Sul, Brazil, and the danger of power lines to howlers in urban reserves. *Neotropical Primates* 4: 135–136.
- Ram C, Sharma G, Rajpurohit LS (2015). Mortality and threats to Hanuman langurs (*Semnopithecus entellus entellus*) in and around Jodhpur (Rajasthan). *Indian Forester* 141: 1042–1045.
- Rodrigues NN, Martinez R (2014). Wildlife in our backyard: interactions between Wied's marmoset *Callithrix kuhlii* (Primates: Callithrichidae) and residents of Ilheus, Bahia, Brazil. *Wildlife Biology* 20: 91–96.
- Roscoe CJ, De Silva M, Hapuarachchi NC, Krishanta RPA (2013). A new color morph of the southern purple-faced langur (*Semnopithecus vetulus vetulus*) from the rainforests of southwestern Sri Lanka. *Primate Conservation* 26: 115–124.
- Rudran R (2007). A survey of Sri Lanka's endangered and endemic western purple-faced langur (*Trachypithecus vetulus nestor*). *Primate Conservation* 22: 139–144.
- Singh M (2019). Management of forest-dwelling and urban species: case studies of the lion-tailed macaque (*Macaca silenus*) and the bonnet macaque (*M. radiata*). *International Journal of Primatology* 40: 613–629.
- Southwick CH, Siddiqi MF, Farooqui MY, Pal BC (1976). Effects of artificial feeding on aggressive behaviour of rhesus monkeys in India. *Animal Behaviour* 24: 11–15.
- Teixeira FZ, Printes RC, Fagundes JCG, Alonso AC, Kindel A (2013). Canopy bridges as road overpasses for wildlife in urban fragmented landscapes. *Biota Neotropica* 13: 117–123.
- Tintó A, Real J, Mañosa S (2010). Predicting and correcting electrocution of birds in mediterranean areas. *Journal of Wildlife Management* 74: 1852–1862.
- Valladares-Padua C, Cullen Jr. L, Padua S (1995). A pole bridge to avoid primate road kills. *Neotropical Primates* 3: 13–15.
- Wheatland Electric Cooperative, Inc., (2014). <http://wheatlandeci.coopwebbuilder2.com/content/wildlife-protection>.